

SPSY

SPSY SERIES SINGLE POINT STAINLESS STEEL LOAD CELLS



Stainless steel load cells for off center loads, suitable for example to build CE-M approved scales with a single load cell with maximum dimensions of 500x400 mm.

CAPACITIES (kg): 50, 100.

OIML R60. C3 precision class.

17-4 PH stainless steel. IP68 protection.

Working in cooperation with:

SC DATA SPEED SRL

STR DONATH N. 115/33 - 400331 - JUD. CLUJ
Tel. 0040-264566473 Fax. 0040-364-815440
office@cantare.com.ro

The best solution
for advanced industrial
applications

MAIN FEATURES

- C3 PRECISION CLASS
- OFF CENTER LOAD COMPENSATED
- MADE IN 17-4 PH STAINLESS STEEL
- IP68 PROTECTION
- MAX. CAPACITIES FROM 50 TO 100 kg
- FOR PLATFORMS WITH DIMENSIONS UP TO 500 X 400 mm
- SHIELDED CONNECTION CABLE
- TEST CERTIFICATE AVAILABLE UPON REQUEST

TECHNICAL FEATURES

- Minimum load cell verification interval: $V_{min} = E_{Max} / 10.000$
- Maximum number of verification intervals: $n_{LC} = 3000$
- Full Scale Output: $2mV/V \pm 10\%$
- Temperature effect on zero: $0,01\% FS/10K$
- Temperature effect on full scale output: $0,001\% FS/10K$
- Compensated Temperature Range: $-10^{\circ}C/+40^{\circ}C$
- Operating Temperature Range: $-10^{\circ}C/+50^{\circ}C$
- Creep at nominal load in 30 minutes: $\pm 0,01\% F.S.$
- Maximum tolerated excitation voltage: 15 VDC
- Input Resistance: $380 \pm 15 \text{ Ohm}$
- Output Resistance: $350 \pm 10 \text{ Ohm}$
- Insulation Resistance (100V) $>2000 \text{ MOhm}$
- Safe Overload: 300% F.S.
- Ultimate Overload: 300% F.S.
- Nominal displacement: $< 0.5 \text{ mm}$
- 6-wire shielded cable, 3m long, 5mm diameter

DETAIL 1

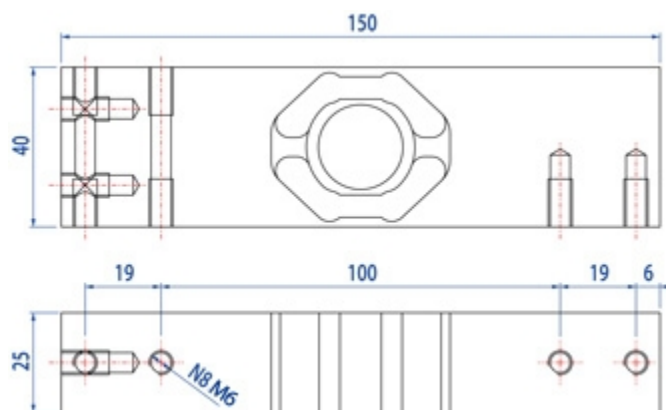



Dimensions in mm

Wiring Code	
<i>Colour</i>	<i>Function</i>
WHITE	OUTPUT +
GREEN	SENSE +
BLUE	INPUT +
RED	OUTPUT -
BLACK	INPUT -
GREY	SENSE -

VERSIONS

Versioni disponibili

Codice	Piatto Max (mm)	Max (kg)
SPSY50 	500 x 400	50
SPSY100 	500 x 400	100



www.diniargeo.com



“YOUR WORLDWIDE PARTNER FOR WEIGHING,”

DINI ARGEO
FRANCE sarl
Nogent-sur-Marne

DINI ARGEO
GMBH
Sinsheim - Germany

DINI ARGEO
UK Ltd
Taunton - United Kingdom

DINI ARGEO WEIGHING
INSTRUMENTS Ltd
Shanghai - China

DINI ARGEO
WEIGHBRIDGES
Calto (RO) – Italy



HEAD OFFICE
Via Della Fisica, 20
41042 Spezzano di Fiorano Modena - Italy



SC DATA SPEED SRL

STR DONATH N. 115/33 - 400331 - JUD. CLUJ

Tel. 0040-264566473 Fax. 0040-364-815440

office@cantare.com.ro

SALES AND TECHNICAL ASSISTANCE SERVICE